

Logistic Requirements for
Cross Docking Delivery
to

Non Food II
Logistics Platform Austria

Located at SIMPEX Wr. Neudorf

Non Food II Logistics Platform Austria

- Located at SIMPEX Wr. Neudorf
- ## LOGISTIC REQUIREMENTS

Point of delivery /contact Non Food II Logistics Platform Austria

NF II Logistikplattform Austria
Industriezentrum NÖ-Süd
Straße 14, Objekt 24, Tor 4
A-2355 Wiener Neudorf
Tel. office: +43 (0) 662 4470 39539
Tel. Warehouse: +43 (0) 662 4470 39551
FAX: +43 (0) 662 4470 39599
E-Mail: wareneingang@simpex.at

GLN: 9100500008207

For CD3 delivery it's necessary to note the GLN – number in the address field.

Directions scetch:



Non Food II Logistics Platform Austria

– Located at SIMPEX Wr. Neudorf

LOGISTIC REQUIREMENTS

Dispatch notification:

After assignment from the purchasing department please send us an e-mail to confirm the delivery (at least seven working days before the actual delivery date):

to: wareneingang@simpex.at

In this e-mail you have to announce us the following **logistic details**:

- ❖ **Packing List per Interspar or/and Eurospar market (only for Cross Docking 1)**
- ❖ **Delivery note / Bill of Lading per TU**
- ❖ **Information if it's truck or container delivery**
- ❖ **In case of container delivery you have to announce the container number**

→ These information has to be send BEFORE delivery to wareneingang@simpex.at.

In case of delivery by a forwarding agent in trucks, apart from the information above, the following information shall be communicated to Simpex.

- ❖ Name of the carrier
- ❖ Number of pallets and/or information if the delivery is going to be effected in bulk

Goods will only be accepted if accompanied by shipping documents (packing list, delivery note, CMR,...)!

Non Food II Logistics Platform Austria

– Located at SIMPEX Wr. Neudorf

LOGISTIC REQUIREMENTS

General logistic requirements

All goods ordered by Simpex must fulfill all logistic requirements without exception. The following is to give you a brief overview of the most important requirements:

- All articles must be delivered in the **correct quantity, at the agreed time, and in the right quality as agreed.**
- The **cardboard packages** must provide for **adequate stability** so as to ensure that the goods inside cannot be damaged.
- You are requested to always and exclusively deliver pallets of the same height **(EP200)**.
- For your information: **Unloading a truck will take approx. 2 hours, unloading a full container will take approx. 4 hours.** Please take this into account when making your arrangements. Should unloading take any longer, Simpex will not accept to pay any demurrage to the supplier or forwarder.
- The trading units must also be in conformity with **EUL (efficient unit loads)**, any protrusion or bulging of the goods on the pallets must be avoided. The supplier shall be obliged to load the pallets in such way that their safety and stability during transport is ensured and that the cardboard boxes on the pallets can be stored in a high rack warehouse (height of max. 2m incl. pallet).
- **Transparent packaging foils** shall be used **exclusively** – never black/non-transparent foils.

Delivery date notified to Simpex

If the actual delivery date notified to and agreed with Simpex is not observed, no unloading by Simpex can be guaranteed for the following day. Generally, Simpex will try to make unloading possible. Any extra cost incurred by Simpex (staff resources provided for the planned delivery date, storage space reserved...) due to the shift will be charged to the supplier.

The delivery time windows agreed with Simpex have to be observed. Opening hours for delivery to Simpex warehouse daily from 6 a.m. to 14 noon, with every supplier receiving a fixed time window upon notification. Any shifts must be communicated to Simpex already at the time they become known, in order to allow for arrangements to be modified accordingly.

Non Food II Logistics Platform Austria

- Located at SIMPEX Wr. Neudorf
- ### LOGISTIC REQUIREMENTS

Logistic Requirements with respect to loading aids for delivery by truck

Loading aids are transport aids (transport packaging) by means of which several dispatch units can usually be shipped, stored or positioned.

1. Requirement: Use of standardized reusable pallets

Onyl EURO pallets with the following dimensions:

- length 1,20 m
- width 0,80 m

Die EURO-Palette 1200 x 800 mm

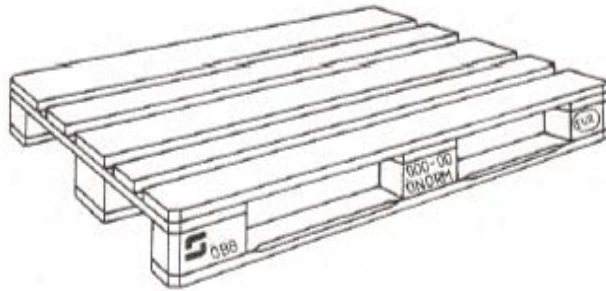

The EURO pallet 1200 x 800mm

2. Requirement: Observance of maximum loading heights

Stability during transport must be guaranteed!

Protrusion of goods on pallet max. 3cm!

Maximum pallet height (incl. pallet): 2,00 meters

Non Food II Logistics Platform Austria

– Located at SIMPEX Wr. Neudorf

LOGISTIC REQUIREMENTS

Empties handling

The number of reusable pallets delivered will be exchanged for empty pallets directly upon unloading of the truck (unless any other agreement was made).

If, for any reason, the supplier or Simpex is not able to exchange the pallets, the forwarder / supplier will be issued an empty pallet credit note with respect to the quantity not replaced.

PLEASE NOTE: The credit note is issued to the supplier (not the forwarder!) and must be redeemed within the following 3 months, as afterwards the credit note will cease to be valid and the supplier shall no longer be entitled to the EURO pallets. Damaged pallets and pallets no longer suitable for use will not be accepted for exchange, if:

1. a board is missing or broken diagonally or transversally.
2. a board (top or bottom board) is splintered in such a way that more than one nail or screw shank is visible.
3. more than two boards (top or bottom board) are splintered in such a way that one nail or screw shank is visible in each case.
4. a block is broken or splintered in such a way that more than one nail or screw shank is visible.
5. not at least one mark of the rail / pallet organization and one „EUR“ marking are visible.
6. clearly inadmissible components have been used for repair (e.G. boards or blocks that are too thin, too narrow, too short).
7. the general condition is so poor that the pallets suitability to carry goods is no longer ensured (e.g. rotten boards/blocks,...) or the goods might be soiled.

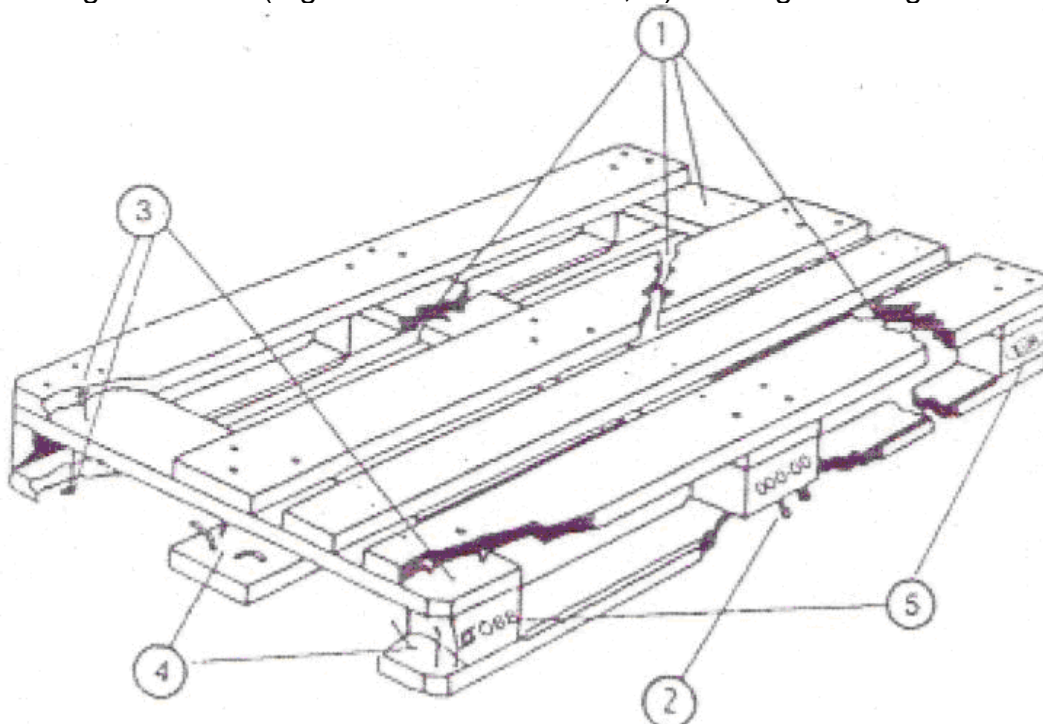

Non Food II Logistics Platform Austria

– Located at SIMPEX Wr. Neudorf

LOGISTIC REQUIREMENTS

Product labeling

1. GVE (wholesale unit)

Required product labeling of the wholesale unit: EAN 13 barcode, supplier article number, product name and amount of content

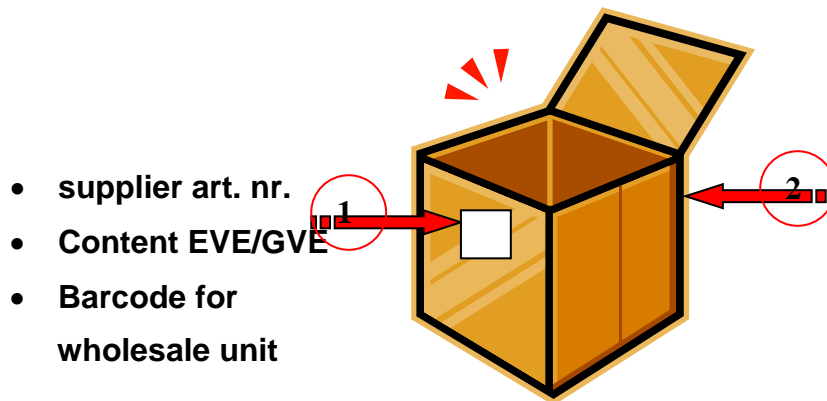

2. EVE (retail unit)

Declaration on the retail unit with EAN 13 barcode

Non Food II Logistics Platform Austria

- Located at SIMPEX Wr. Neudorf
- ## LOGISTIC REQUIREMENTS

Explanation Cross Docking III – multilevel

Delivery of items
Per pure pallets
(no mixed pallets)
by the supplier
(one item per pallet)

Picking of several
items for customer
pallets at the NF 2
platform

Distribution of
customer pallets
to the ISP and
ESP

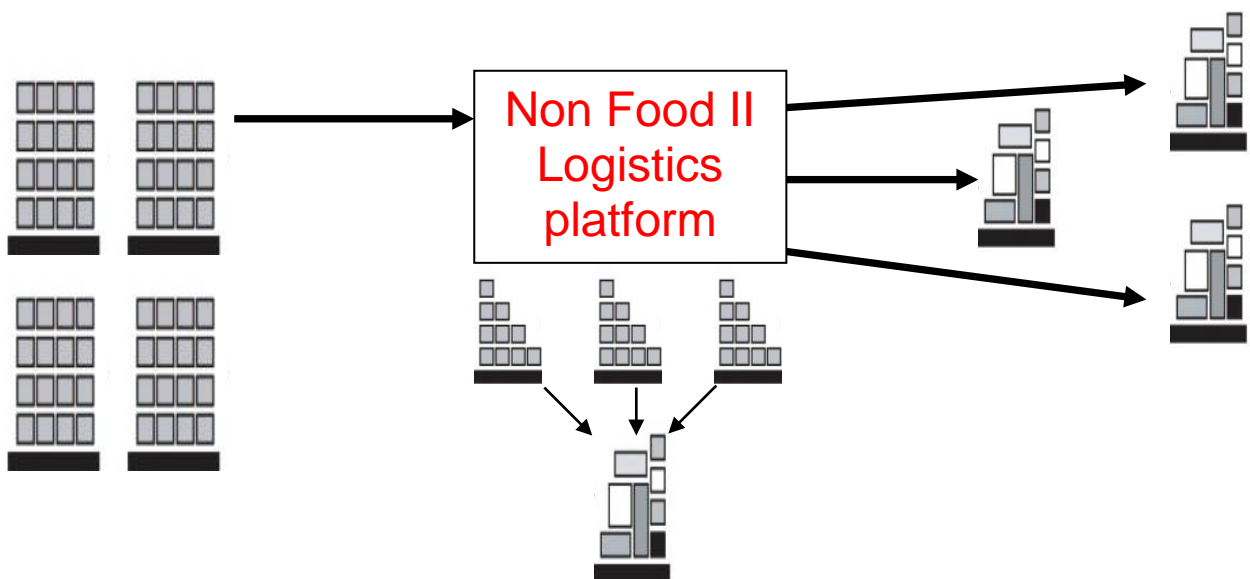

Penalty Payments

With repeated non-compliance of the listed criteria, we reserve the right to ask for penalties for the expenses incurred.

- no / incorrect/ unreadable GS1-128/EAN-13 on the GVE	0,37 Euro / GVE
- no / incorrect / unreadable GS1-128+SSCC on the pallet (SSCC) (only for no mixed pallets)	5 Euro /pallet
- repacking expenses → stability of pallets – <i>pallets, wich tend to threaten to fall, poor transport safety, damaged pallets etc.</i>	20 Euro per pallet (for repacking expenses)
- repacking expense when an article is delivered on several	10 Euro per pallet

Non Food II Logistics Platform Austria

– Located at SIMPEX Wr. Neudorf

LOGISTIC REQUIREMENTS

pallets	
- exceeded maximum pallet height 2,20 meters (incl . pallet)	10 Euro per pallet
- nature of the cardboard packages – GVE unstable, bowing to pressure etc.	0,50 Euro / GVE
- no order number on the delivery note	25 Euro per CMR
- delivery outside of the agreed delivery day	10 Euro per pallet