

# Logistics handbook for suppliers of the central warehouse Wels (ZLW)

Assortment: Dry Goods and Non-Foods

Version: December 2024

## History of changes

Version	Changes	Page
December 2024	New opening-hours for inbound.	Page 7
September 2023	Renaming Mercareon to Transporeon	Page 6
May 2023	Adjustment of amount billed Adjustment of amount billed	Page 19 Page 22

# Table of Contents:

1. [Important notice for new suppliers](#)
2. [Delivery Process in all SPAR Warehouses](#)
  - [2.1 Details Central Warehouse Wels](#)
3. [Conditions for Delivery Processing](#)
  - [3.1 Loading Aids](#)
  - [3.2 Pallet Quality](#)
  - [3.3 Pallet Goods-Shifting](#)
  - [3.4 Pallet Heights](#)
  - [3.5 Pallet Weight](#)
  - [3.6 Condition of the pallet](#)
  - [3.7 Condition of the packaging](#)
  - [3.8 Delivery note](#)
  - [3.9 Displays and Dollys](#)
  - [3.10 Dangerous Substances](#)
4. [Labelling](#)
  - [4.1 Pallet Labelling](#)
  - [4.2 Examples of Delivery Notes \(DIN A5\)](#)
  - [4.3 Placement of the pallet labels](#)
  - [4.4 WPU \(Wholesale -Packing-Unit\)](#)
  - [4.5 RPU \(Retail Packing Unit\)](#)
  - [4.6 Barcode quality](#)
5. [Electronic Data Interchange with SPAR](#)
6. [Safety measurements at Goods Receiving](#)

# 1. Important notice for new suppliers

- In order to avoid any problems in advance, please contact the Logistics Department prior to the first delivery.
- SPAR Österr. Warenhandels AG, Zentrallager Wels, Terminalstraße 85, A-4600 Wels
  - Gerhard Kroiss
    - Tel.: +43 7242 25403 521
    - E-Mail: [gerhard.kroiss@spar.at](mailto:gerhard.kroiss@spar.at)
  - Sonja Sommerhuber
    - E-Mail: [sonja.sommerhuber@spar.at](mailto:sonja.sommerhuber@spar.at)
- Additionally, the registration on our B2B Portal is necessary (<http://b2b.spar.at>). There you also always find the latest version of our logistics handbook.

# Delivery Process in all SPAR Warehouses

## **Goods Arrival:**

The goods arrival can occur by truck in all SPAR Warehouses. The goods arrival by bus, car or any other small vehicle is not allowed and will lead to a rejection of the delivery.

## **Standard Delivery Condition for all regional Warehouses:**

Delivery by truck behind first free lockable door or if existing onto the free conveyor equipment (Furthermore the SPAR Company general terms of delivery apply). For the unloading of the goods the suppliers will be supplied with manual pallet lifters, electrical pallet lifters and double-pallet fork-lift trucks.

## **Punctuality of Deliveries:**

All delivery dates, which are agreed with SPAR, must be met. Trucks, which arrive on the wrong date, can be rejected by the goods arrival.

# Timeslotmanagement - Transporeon

- In order to guarantee a punctual unloading at the SPAR warehouses and to avoid stand by times, there is the possibility of time slot reservation with Transporeon time slot management.
- Via the Transporeon internet portal delivering carriers have the possibility to view the available time slots for a specific delivery and to book the most adequate slot.
- SPAR can only accept the booked time-slot, if it corresponds with the date of delivery for the order. Bookings of timeslots days before or after the agreed-on date of delivery cannot be accepted by SPAR.
- Please find more information at <https://www.transporeon.com/de>.

## 2.1 Details Central Warehouse Wels

### SPAR Österr. Warenhandels AG, Zentrallager Wels

Delivery Area	Austria
Address	Terminalstraße 85, A-4600 Wels
GLN	91 00400 00000 4
Acronym	ZLW

### Contact Information

Name	Phone-Number	E-Mail
Gerhard Kroiss Head of flow of goods department	+43 7242 25403 521	gerhard.kroiss@spar.at
Sonja Sommerhuber		sonja.sommerhuber@spar.at
Josef Wolf Incoming goods manager	+43 7242 25403 522	josef.wolf@spar.at
Richard Stockinger Deputy incoming goods manager	+43 7242 25403 523	Richard.stockinger@spar.at

### Incoming Goods – Arrival Times from 07.01.2025

Monday-Friday	04:30-16:00
Saturday-Sunday	Closed





# Conditions for Delivery Processing



# 3.1 Loading Aids

Accepted loading aids:

CHEP Pallet (B1208A)	Europool Pallet (DIN EN 13698-1)
	
<p>SPAR strongly prefers the use of the CHEP Europallet (B1208A), with the overall dimensions of 1200 mm x 800 mm. In this rental system, no pallet exchange is needed. The empty pallets are collected directly from the regional warehouses by employees of the CHEP company for redistribution.</p>	<p>As a further loading aid SPAR accepts the Europool Pallet (DIN EN 13698-1). They are processed as described below (pallet processing).*</p>

SPAR does not accept other loading aids. If the loading aid does not comply with the above-mentioned loading aid, SPAR will charge the supplier for the costs incurred for changing the loading aid (EUR 20.- per pallet).

\* Exceptions:

- Should there, in exceptional cases, not be enough empty pallets for an exchange with the supplier, SPAR will retain the pallets as a gratuitous loan from the supplier. The truck driver will receive a confirmation with which the reclaim can be asserted. Reclaiming pallets is possible at any time during the following three months as soon as the !Original! confirmation is produced. This rule is only applicable at the relevant Regional Warehouse – this means that a confirmation from Wörgl cannot be redeemed at St Pölten etc. For reasons of accounting and stock keeping confirmations older than three months can not be redeemed. The possibility to reclaim will expire after three months. Should the exchange not be possible on the part of SPAR, the confirmation will be extended for further three months.

## 3.2 Pallet Quality

### SPAR will not accept or exchange pallets on which:

1. a board is missing, or broken either diagonally or straight across
2. a base or decking is so damaged or splintered that a nail or a screw is projecting
3. a block is missing or broken or so splintered that screws or nails are visible.
4. there is not at least one identification symbol (EUR and pool-keeper logo) on each long side that is legible.
5. the general condition is so bad that the load - bearing capacity is not guaranteed or where the loaded goods could be damaged or soiled.

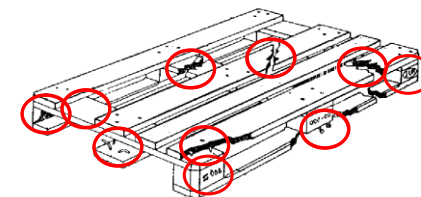

#### Attention:

An optimal quality of pallets enables an efficient flow of goods in the whole supply chain. In case of a poor pallet quality entry on material-handling equipment is not possible, the risk of breakage is high and goods and in the worst-case consumers can be harmed by wooden splinters, projecting nails and extraordinarily dirty pallets.

Deliveries on poor quality pallets can be rejected by goods receiving, in order to accelerate the goods receiving process.

If the pallets don't meet the SPAR criteria, the supplier will be charged the additional work (EUR 20.- per pallet).

That is also valid for CHEP Pallets, which are distributed over cheaper rental models like the pickup from wholesalers. Such models can lead to a poorer CHEP pallet quality, because of not every pallet being checked and repaired at the CHEP service center. Due to cost and environment reasons this is of course reasonable, but it must not lead to a bad pallet quality. Therefore, every supplier has to check the pallet quality prior to sending, otherwise additional expenses occur in the goods arrival. In case of an accumulation of damaged CHEP pallets we will charge it.

The number of defective pallets and the signature of the goods receiving personnel on the bill of delivery serve as a proof. SPAR has no burden of proof by photographs.

**The number of defective pallets and the signature of the goods receiving personnel on the bill of delivery serve as a proof. SPAR has no burden of proof by photographs.**

## 3.3 Pallet Goods-Shifting

+ 0 cm

+ 0 cm

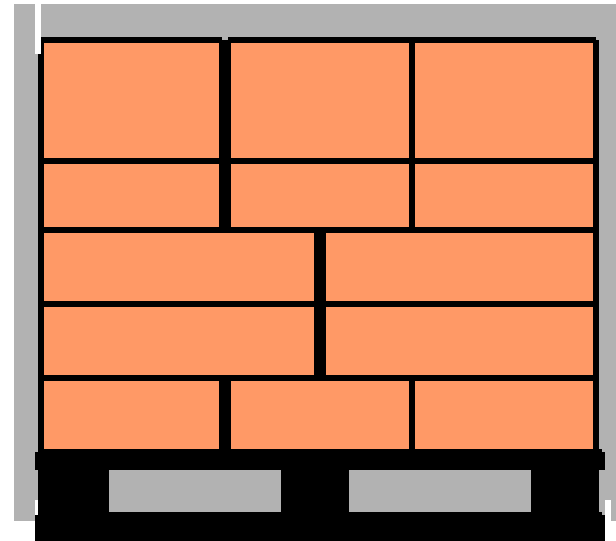

There must not be a pallet goods-shifting, because otherwise the pallet cannot be placed onto the conveyor.

## 3.4 Pallet Heights

All warehouses are equipped according to EUL pallet heights.

The pallet heights are

ECR-Name	EUL-Overall heights incl. Pallet	
EUL 2	2250 mm	2100 mm product + 150 mm pallet
EUL 1,4	1620 mm	1470 mm product + 150 mm pallet
EUL 1	1200 mm	1050 mm product + 150 mm pallet
EUL ½	675 mm	525 mm product + 150 mm pallet
EUL ⅓	500 mm	350 mm product + 150 mm pallet

## 3.5 Pallet Weight

The total weight of a pallet may not exceed **950 kg**.

## 3.6 Condition of the pallet

- Every change of the pallet in terms of how the goods are placed on the pallet or the number of goods per layer or per pallet has to be reported in advance.
  - [Gerhard.kroiss@spar.at](mailto:Gerhard.kroiss@spar.at)
- The goods have to be placed on the pallet without overhang, but using the full space of the pallet.
- The layers have to be stacked in a way to avoid any building of a tower.
- The amount of one article per layer has to be the same.
- All goods within one pallet need to have the same best before date and the same batch number.
- If the same article is part of different orders, it has to be delivered on different pallets.
- The pallets must not be stacked so high, that the bottom layers are damaged.
- If at least the amount of one layer is ordered for one article, it has to be placed on a separate pallet. It is allowed to have sandwich pallets.
- Slipsheets are not welcome and must only be used, if there is no other possible change to stabilize the pallet.
- Plastic foil and paper in between the layers must not be used.
- Only transparent plastic foil must be used, an edge protection is not allowed.

If the condition of the pallet does not meet our requirements, the supplier will be charged the additional work.

## 3.7 Condition of the packaging

- Every change of the packaging has to be reported in advance.
  - Gerhard.kroiss@spar.at
- The wholesale packaging unit has to be closed and compact. The handling in every situation has to be possible, without the danger of goods falling out.
- All Goods in shrinking foil must have the smallest possible window on the side to avoid goods falling out.
- If Shelf Ready Packaging is applied, the unit must be at least as stable and the view window as small to avoid goods falling out.
- If a lid is used, the connection to the carton must be as strong, that the whole weight of the carton is carried. The lid must not get apart from the carton.
- The size of the wholesale packaging unit should be adjusted to the size of the retail packaging unit.
- If the packaging is in not in compliance to the above mentioned items, it has to be authorized.
  - Gerhard.kroiss@spar.at
- If the condition of the packaging does not meet our requirements, the supplier will be charged the additional work.



## 3.8 Delivery note

- For a proper goods arrival in the central warehouse a correct delivery paper is needed, on which the SPAR order number, the exact article description and the amount has to be quoted. For each SPAR order number a delivery note has to be handed over to the bureau of the goods arrival.
- If the delivery note is not meeting our requirements, is missing or is placed on the goods, SPAR reserves the right to charge the supplier EUR 25,-.

## 3.9 ¼ Displays and Dollies

- A handling of displays and dollies in the central warehouse is not possible. These types of articles are only handled in the regional warehouses.
- Displays which exceed the weight of 25 kg must be delivered - without exceptions - on dollies.



## 3.10 Dangerous Substances

- The regulations of the ADR governing limited amounts (“Consumer packaging”) must be followed
- A summary of the most important points as an extract from the aforementioned regulations:
- Dangerous goods counted as limited amounts if they are packaged and labelled according to the ADR:
  - Packaging must be composite packaging i.e. numerous internal packages within an external package:
  - numerous inner packaging within an outer packaging: for instance, in a box or
  - numerous internal packaging in trays, combined into a packing unit with stretch (cling) or shrink film (Caution: only with use of inner packaging made out of metal or plastic – not for inner packaging made out of a different material like glass, may a stretch or shrink film be used instead of an outer packaging.)
- The amount limits (dependent upon the dangerous goods transport classification system) may not be exceeded:
  - for the highest allowable material amount per internal packing unit
  - in part, also the highest allowed material amount per transport item
  - in part additionally, for the highest allowed total mass of the transport item (i.e. the total mass of trays may generally not exceed 20 kg in total.)
- The transport items (packets or trays) must be clearly and permanently marked:
  - with the ID number of the contained goods prefixed with the letters “UN”:
  - with various goods with different ID numbers in the same transport item: with the ID numbers of the contained goods prefixed with the letters “UN” or with the letters “LQ”.
  - This ID marking must be framed by a black line, creating a square balanced on it’s point with a side length of at least 100 mm; if the size of the transport item requires, this label may have smaller dimensions as long as it remains clearly visible.
- This labelling must be visible at all times. Therefore, each labelling of transport items must also be affixed to out packaging (i.e. wrap or shrink film for securing stacked items on a pallet) if this makes the direct labelling of the transport items no longer visible.

# Labelling

Please send us a sample label (Pallet and WPU) for testing prior to the first delivery.  
If you generate a GS1 barcode for the first time, please contact the GS1 organisation of your country,

## **Approval:**

SPAR Österr. Warenhandels AG Zentrallager Wels, Terminalstraße 85, 4600 Wels

Melanie Kiefer

Tel. +43 7242 25403 528

E-Mail: [melanie.kiefer@spar.at](mailto:melanie.kiefer@spar.at)

Sonja Sommerhuber

E-Mail: [sonja.sommerhuber@spar.at](mailto:sonja.sommerhuber@spar.at)

Gerhard Kroiss

Tel. +43 7242 25403 521

E-Mail: [gerhard.kroiss@spar.at](mailto:gerhard.kroiss@spar.at)

Please visit <http://www.gs1.at> for further information.

## **Contact GS1 Austria**

GS1-Austria

Brahmsplatz 3, 1040 Wien

Gerald Gruber, Tel: +43 1 505 8601 43

E-Mail: [gruber@gs1.at](mailto:gruber@gs1.at)

# 4.1 Pallet Labelling

SPAR requires the labelling of all pallets with the GS1-128+SSCC pallet label.

If the GS1-128 and the SSCC are missing or are encoded falsely, SPAR will charge the supplier EUR 5.5 per pallet.

## Data Content:

- SSCC - Number of the pallet AI (00)
- the GTIN-Number of the secondary packaging (Wholesale P U) AI (02)\*
- the best before date – if available AI (15)
- the batch number – if available AI (10)
- amount of secondary packaging (WPU) on the pallet AI (37)

\*The GS1-128+SSCC label must comprise the WPU GTIN which was agreed on with SPAR. Displaying other GTINs, for example the GTIN Number of the over packaging is not permitted.

## Module width / Barcode height:

Width: 0,495 – 1,016 mm

Height: 32 mm

## Sticker/Label format (Recommendation):

DIN A5 210 x 148 mm (H x W)

## 4.2 Examples of Delivery Notes (DIN A5)

MUSTERUNTERNEHMEN

**LOGO**

Straße

Ort

### Produktbeschreibung

SSCC: **390123450000000012**

CONTENT  
(GTIN der Handelseinheit): **9012345000028**

COUNT  
(Menge der Handelseinheiten): **120**

BEST BEFORE  
(Mindesthaltbarkeitsdatum): **21.05.2023**

BATCH/LOT  
(Los/Charge): **A12345678**

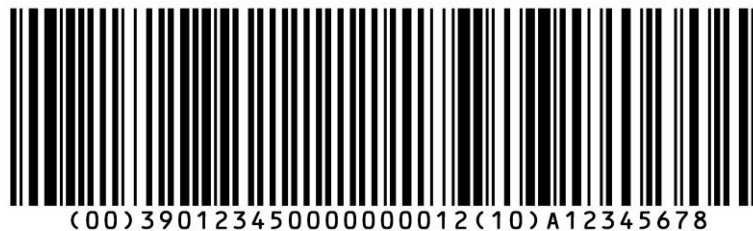

## 4.3 Placement of the pallet labels

- According to the ECR handbook, the GS1 transport-label must be applied 400 - 800mm from the floor and at least 50 mm from the side. On transport secured pallets the sticker must be attached to the plastic film. One label must be applied on the narrow side and one on the long side to the right hand side of it.
- On low pallets it is allowed to bend the text field over the edge onto the top. The barcode part must be scan able without any further manipulation (ECR documentation „Harmonisierung GS1-128 – GS1 Transportetikett“).

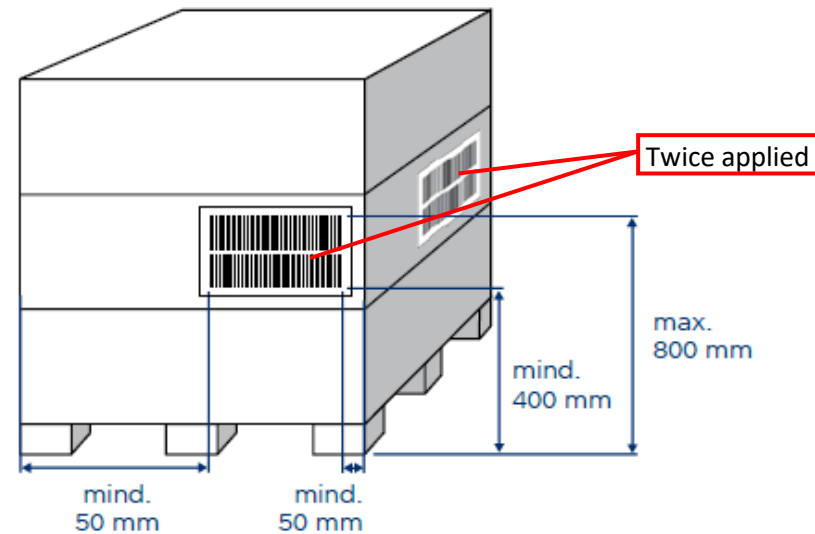

## 4.4 WPU (Wholesale -Packing-Unit)

Basically, secondary packaging should be labelled with clear text as well as with a barcode (EAN-13, ITF-14, UPC-A, GS1-128 mit GTIN).

The content must be clearly and visibly stated. This facilitates the allocation of the goods to the bill of delivery. The product number, name and the number of single trade PKUs must be displayed.

The labelling must be done according to GS1 standards, on two sides of the packaging.

**Should the labelling with EAN-13, ITF-14 or GS1-128 be missing or be encoded falsely, SPAR will charge the supplier a surcharge of EUR 0.40 per unit.**

**Examples of Labels:**





## 4.5 RPU (Retail Packing Unit)

Labelling with the following barcode is accepted:

- EAN-8
- EAN-13
- UPC-A

Examples of labels:

 9 0 9 9 9 1 2 3	 9 0 1 2 3 4 5 0 0 0 0 1 1 >	 0 1 2 3 4 5 6 7 8 9 1 2
EAN-8	EAN-13	UPC-A

## 4.6 Barcode quality

In order to ensure fast and efficient scanning processes at the cash registers and in SPAR wholesale-fulfillment centers, the following quality requirements of the barcodes are needed:

The attached bar code symbol must have at least the following overall symbol class according to **ISO / IEC 15416**:

The attached barcodes must have an overall symbol class of at least **1.5** according to ISO / IEC 15416 (test specification for barcode quality), the barcode must also correspond to the respective specifications of the barcode symbology.

To ensure optimal readability of the barcodes, SPAR recommends an overall symbol **classification of 2.5**.

For your information: A barcode can be rated between 0 and 4 with a test device. According to ISO / IEC 15416 a rating of 4 is the best value. The check can be carried out by an GS1 organization such as GS1 Austria ([www.gs1.at/stichcodepruefservice](http://www.gs1.at/stichcodepruefservice)).



# Electronic Data Interchange with SPAR

SPAR provides the possibility of interchanging data electronically. The supported messages are orders, Despatch Advice (for warehouses and direct deliveries) and Invoice.

In our Warehouses we set a high value into the DesAdv. This electronic message enables precise planning and processing at the goods receiving and thus accelerates the process. This results in shorter waiting times.

Therefore, we expect our partners to transmit electronic bills of deliveries which accord to today's standards.

BEWARE! In order to use DesAdv's, the correct use of the GS1-128 label on the pallets is absolutely necessary.

Information on the composition of Despatch Advices can be found on our B2B Portal using the following [Link](#) or by accessing through the B2B-portal (<http://b2b.spar.at>).

In the Warehouses we require the hierarchical DesAdv incl. SSCC.

If the transferred data (expiry date, quantity and batch) from the DesAdv is not correct or the whole DesAdv is missing, SPAR charges the additional expenses of EUR 100,-.

# Safety measurements at Goods Receiving

## Warehouse Premises

- Driving with an open auto hoist on SPAR warehouse premises is forbidden.
- The road transport regulation is applicable on warehouse premises, with a maximum speed of 10 km/h and keeping to the right. Please beware of human traffic.
- The parking of vehicles is only permitted in the designated areas and only until unloading.

## Goods receiving

- Follow the instructions of the goods receiving personnel.
- Access is only granted to the goods receiving area. All other areas of the warehouse may only be accessed when permitted.
- Before unloading the supplier has to register with the responsible goods receiving and show bill of lading and bill of delivery.
- The automatic lifting ramps are to be operated accordingly. Should the truck driver have no experience with these he must announce this to the SPAR personnel who will brief him.
- The unloading has to be carried out by the supplier.
- The unloading is only permitted with safety shoes.
- Should the pallet quality not comply with the standards of SPAR, the pallet will not be exchanged.



# Safety measurements at Goods Receiving

## General

- The handling of SPAR owned electronic devices takes place at the users' risk. The supplier is liable for all damage occurred. Accidents and damage are to be announced to the goods receiving supervisor immediately and a report of the accident has to be written.
- All waste has to be removed accordingly.
- Smoking in the hall and the drinking of alcoholic beverages everywhere on the warehouse premises are strictly forbidden.
- Beware of frequent traffic with electronic devices at goods receiving.
- In case of a fire alarm, obey the instructions of SPAR personnel.
- Emergency exits have to be free at every time.

